

User Manual

Police-Lab® 8.46"/10.1" Touchscreen Upgrade for 2020-2024 Ford Police Interceptor Utility (with SYNC)



Init. Release Date:

June 4, 2025

Rev. Date:

June 4, 2026

Rev. Version:

V2.1

Manual ID:

UM-PL-20FPIU-UP3

POLICE-LAB

Copyright and Usage Notice:

This document is the intellectual property of Police-Lab and is intended solely for use by authorized technicians or end users. No part of this publication may be reproduced, distributed, or transmitted in any form or by any means without the prior written permission of Police-Lab. All product names, logos, and trademarks are property of their respective owners. This manual is provided for informational purposes only and may be subject to revision without notice. Always refer to the latest version available at www.police-lab.com.

Ford, Lincoln, the Ford logo, the Lincoln logo and all Ford-and-Lincoln-designed and manufactured vehicle products, including related computer-generated images, are copyrighted materials owned by Ford Motor Company and Lincoln Motor Company. Police-Lab is not affiliated with Ford Motor Company and Lincoln Motor Company in any way.

Table of Contents

TABLE OF CONTENTS	2
1. INTRODUCTION	3
2. PACKAGE CONTENTS	4
2.1 COMPONENTS INCLUDED	4
2.2 COMPONENTS MAY BE INCLUDED – DEPENDING ON YOUR ORDER OPTION	4
2.3 COMPONENTS NOT INCLUDED – REQUIRED FOR INSTALLATION	4
3. TOOLS REQUIRED	6
4. VEHICLE COMPATIBILITY	7
5. SAFETY DISCLAIMER	8
5.1 IMPORTANT SAFETY INFORMATION — READ BEFORE INSTALLATION	8
5.2 QUALIFIED INSTALLATION RECOMMENDED	8
5.3 DISCONNECT BATTERY BEFORE BEGINNING	8
5.4 STATIC DISCHARGE PRECAUTIONS	8
5.5 DO NOT MODIFY OR FORCE COMPONENTS	8
5.6 AVOID CONTACT WITH AIRBAG SYSTEMS	8
5.7 DO NOT POWER ON THE VEHICLE WITH INCOMPLETE CONNECTIONS	8
5.8 POST-INSTALLATION VERIFICATION IS MANDATORY	9
6. PANEL REMOVAL, MODULE INSTALLATION & WIRING INSTRUCTIONS	10
6.1 DETAILED PANEL REMOVAL & MODULE INSTALLATION PROCESS	10
6.2 DETAILED DISPLAY INSTALLATION PROCESS	17
6.3 VIDEO TUTORIAL	19
7. VEHICLE-SPECIFIC ADVISORY	21
8. POST-INSTALLATION SETUP	22
9. MODULE PROGRAMMING & UPDATE	23
10. PRODUCT LABEL IDENTIFICATION & RETENTION REQUIREMENTS	27
11. WARRANTY AND TECHNICAL SUPPORT	29
12. CONTACT INFORMATION	30

1. Introduction

The 8.46"/10.1" Touchscreen Upgrade Package for the 2020–2024 Ford Police Interceptor Utility (with SYNC) is a vehicle-specific, professionally engineered display enhancement designed exclusively for vehicles equipped with factory option 65U (Police Interior Upgrade Package).

This system is not a generic infotainment retrofit. It is developed specifically for 65U-configured FPIU platforms where the factory SYNC architecture and OEM electronic systems are already present, allowing this upgrade to focus on expanding and modernizing the in-vehicle display and user interface experience.

By integrating directly with the factory SYNC environment, this package enables access to modern OEM-grade infotainment features including Apple CarPlay®, Android Auto™, integrated navigation, and enhanced Ford interface functionality. The result is a significantly improved driver interaction experience while maintaining full compatibility with existing vehicle systems.

At the core of the system is a Ford SYNC-compatible APIM (Accessory Protocol Interface Module), pre-configured to work within Ford's factory network architecture. Paired with an OEM 8.46" or 10.1" high-resolution capacitive touchscreen, the system delivers a responsive and intuitive interface designed for operational efficiency in both fleet and individual use cases.

The display is supported by a custom-engineered mounting and bezel assembly developed specifically for the 2020–2024 FPIU platform. This ensures proper integration with factory HVAC controls, audio interfaces, and dashboard ergonomics while maintaining a secure and OEM-aligned fitment.

This upgrade is intended for:

- Fleet agencies standardizing in-vehicle user interfaces across patrol units
- Municipal and service vehicles equipped with option 65U requiring modern display functionality
- Professional users seeking OEM-integrated infotainment enhancement without altering factory system integrity

All components are pre-tested and validated prior to shipment to ensure system reliability and reduce installation downtime. The installation process is supported by detailed documentation to maintain consistency and repeatability across deployments.

This is a platform-specific display enhancement developed for Ford's 65U-equipped FPIU architecture—focused on improving usability, modern connectivity, and operational efficiency while preserving full OEM system compatibility.

Full details available online at: <https://shop.police-lab.com/products/pl-20fpiu-up3>

2. Package Contents

2.1 Components Included

Component	Product Number	Qty	Note
Welcome card	PL-SUP-WC	1	-
Information card	PL-SUP-IC	1	-
OEM HD capacitive touchscreen display	PL-DISPLAY-846/PL-DISPLAY-101	1	8.46" or 10.1" screen size option is available, depending on your selected option
APIM to USB multimedia hub cable	PL-FORD-USBCABLE	1	-
Custom-fit bezel - base plate	PL-20FPIU-MOUNT1/PL-20FPIU-MOUNT101-1	1	8.46" or 10.1" mounting bezel option is available, depending on your selected option
Custom-fit bezel - screen plate	PL-20FPIU-MOUNT846-2/PL-20FPIU-MOUNT101-2	1	8.46" or 10.1" mounting bezel option is available, depending on your selected option
Custom-fit bezel - screen bezel	PL-20FPIU-MOUNT846-3/PL-20FPIU-MOUNT101-3	1	8.46" or 10.1" mounting bezel option is available, depending on your selected option

2.2 Components May Be Included – Depending on Your Order Option

Component	Product Number	Qty	Note
Custom-fit bezel - screen bezel	PL-20FPIU-MOUNT101-4	1	Exclusive for 10.1" mounting bezel option
SYNC 3 APIM module	PL-SYNC3-V4-NAV/PL-SYNC3-V4-NON	1	Module is pre-programmed. Navigation APIM option is available, depending on your selected option

2.3 Components Not Included – Required for Installation

Component	Product Number	Qty	Note
USB multimedia hub	ML3Z-19A387-D (Ford part number)	1	Some vehicles are equipped with this hub already, please double check if you have this dual-port hub

Hexagon head screw; M6 x 35mm or M6 x 40mm	-	5 or 6	6x full-thread M6 x 35mm screw for 8.46" option, 5x half-thread M6 x 40mm screw for 10.1" option
Flat washer; M6	-	5 or 6	6x for 8.46" option, 5x for 10.1" option
Hex nut; M6	-	5 or 6	6x for 8.46" option, 5x for 10.1" option
Stainless steel Phillips head screw; M4 x 10mm	-	4 or 6	6x for 8.46" option, 4x for 10.1" option
Work gloves	-	As needed	-
Wrench socket set	-	As needed	-
Interior trim panel removal tool	-	As needed	-
Zip ties	-	As needed	-



POLICE-LAB

3. Tools Required

The following tools are recommended to complete the installation safely and efficiently. Ensure all tools are on hand before beginning the procedure:

- Interior trim removal tools – To safely dislodge dashboard and pillar panels without scratching or cracking plastic surfaces.
- Socket and ratchet set – Required for removing OEM modules, mounting hardware, and dash reinforcement brackets.
- Phillips and flathead screwdrivers – For removing various screws securing trim pieces and factory electronics.
- Torx driver set – Often required for module fasteners or screen brackets, especially in Ford factory components.
- Zip ties or Velcro straps – To organize and secure the harness routing behind the dash or console.
- Flashlight or headlamp – Useful for navigating tight or poorly lit areas behind dash panels or under the steering column.



POLICE-LAB

4. Vehicle Compatibility

This product is compatible with the following Ford Police Interceptor Utility (FPIU) models:

- 2020-2024 Ford Police Interceptor Utility, 3.3L Duratec engine, naturally aspirated
- 2020-2024 Ford Police Interceptor Utility, 3.3L Duratec engine, hybrid
- 2020-2024 Ford Police Interceptor Utility, 3.0L EcoBoost engine, twin-turbo charged

⚠ Important: This display upgrade package is designed specifically for vehicles equipped with factory option 65U (Police Interior Upgrade Package). It is not compatible with vehicles that do not come with option 65U. While most FPIU units on the market were not ordered with this option from the factory, some special-service vehicles, admin vehicles, or municipal fleet orders may include it. If your vehicle is not equipped with option 65U, please refer to the alternative upgrade solution: SYNC 3 Upgrade Package for 2020-2024 Ford Police Interceptor Utility. Full details available online at: <https://shop.police-lab.com/products/pl-20fpiu-up1>



POLICE-LAB

5. Safety Disclaimer

5.1 IMPORTANT SAFETY INFORMATION — READ BEFORE INSTALLATION

This installation involves electrical components and direct interaction with critical vehicle systems. To ensure personal safety and to protect vehicle integrity, it is essential that all procedures are performed in accordance with the guidelines provided below. Failure to follow these instructions may result in serious injury, electrical system failure, or permanent damage to the vehicle.

5.2 Qualified Installation Recommended

This upgrade package is intended to be installed by experienced automotive technicians or individuals familiar with Ford vehicle electronics, module programming, and interior disassembly. If you are not confident in your ability to safely install the system, we strongly recommend seeking assistance from a certified automotive electronics professional.

5.3 Disconnect Battery Before Beginning

Always disconnect the vehicle's negative battery terminal before performing any work. This prevents accidental short circuits, module corruption, or airbag deployment. Do not reconnect the battery until all connections are verified and securely fastened.

5.4 Static Discharge Precautions

Vehicle electrical modules are sensitive electronic components. Use proper ESD (electrostatic discharge) handling practices, including grounding yourself and avoiding contact with exposed module pins or circuit boards.

5.5 Do Not Modify or Force Components

All parts provided in this package are precision-engineered to fit the vehicle(s) mentioned in Section 4. Do not attempt to force-fit components or alter wiring to bypass connectors or grounding points. Doing so may compromise system safety, void your warranty, and cause operational issues.

5.6 Avoid Contact with Airbag Systems

Interior disassembly may require removal of trim panels near airbag modules (e.g., knee bolster, A-pillars). Always proceed with caution and follow Ford OEM airbag handling procedures. Never tap into circuits related to SRS (Supplemental Restraint System).

5.7 Do Not Power on the Vehicle with Incomplete Connections

Powering on the ignition with any of the following components disconnected may trigger diagnostic trouble codes (DTCs), system misbehavior, or partial functionality:

- Harness, modules or switches included in the upgrade package

- Existing vehicle harness, modules or switches
- Display interface
- Module antenna(s)

5.8 Post-Installation Verification Is Mandatory

After completing installation:

- Confirm full boot of the vehicle system
- Verify vehicle functions such as backup camera functionality, steering wheel controls, mobile phone projection (Apple CarPlay/Android Auto connectivity), audio system and HVAC etc.

⚠ Important: Police-Lab assumes no liability for damage or injury resulting from improper installation, electrical misconfiguration, or unauthorized modification of the included components.



POLICE-LAB

6. Panel Removal, Module Installation & Wiring Instructions

6.1 Detailed Panel Removal & Module Installation Process

The following pages provide detailed visual and text instructions for vehicle components removal & module installations.

⚠ Important: If you purchased the navigation upgrade option, please begin from Step 1. If you did not purchase that option, please begin from Step 4.

Step 1: Grab your interior trim removal tool and lift the front control cover. Work your way across the edge and pop the plastic panel up to remove it.



Step 2: Remove the three T20 Torx screws securing the APIM to the display assembly. Once removed, set the screws aside as they will be reused during reassembly.

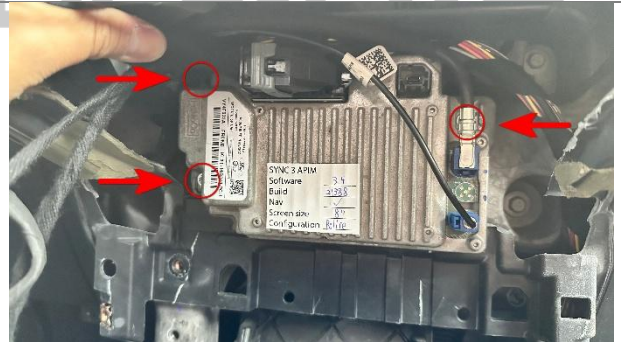

Step 3: Install the new APIM supplied in the package onto the display assembly and secure it using the three T20 Torx screws. Connect all connectors and test-fit the assembly to ensure everything is properly aligned and functioning. Once fitment has been verified, disconnect only the 54-pin APIM primary connector. We'll modify this connector in the next step.



Step 4: Carefully inspect the 54-pin connector. In this instruction manual, it is shown against a white background for clarity and visual reference purposes; however, in the vehicle, this connector will be accessed and modified in its actual installed environment. The white background is used strictly to enhance image visibility and does not reflect the in-vehicle working conditions.



Step 5: Carefully examine the terminal face of the connector. You will notice that the connector is clearly labeled with pin designations, arranged in sequence from Pin 1 to Pin 18, Pin 19 to Pin 36, and Pin 37 to Pin 54. These markings indicate the correct pin order for reference during installation and wiring.



Step 6: Locate the exposed section of the harness as shown in the diagram. You will find two retaining clips on the assembly. First, release the left clip by pushing it outward to the left, and release the right clip by pushing it outward to the right. While both clips are disengaged, carefully pull the entire harness outward to release it from its seated position.

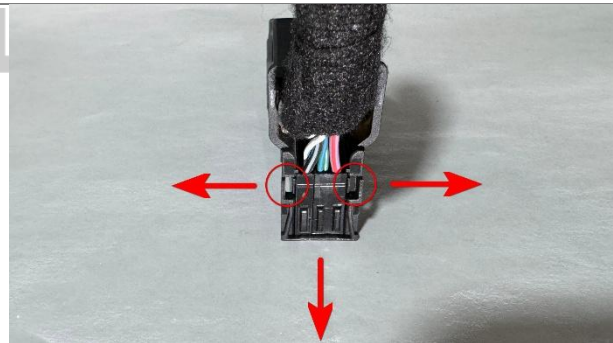

Step 7: After pulling the assembly outward, you will notice that the wiring harness termination is connected to the inner housing (liner). At this stage, it is not necessary to slide the entire inner assembly out. Only partially release it as needed, ensuring the inner liner remains seated within the outer housing while exposing and retaining access to the harness termination point.

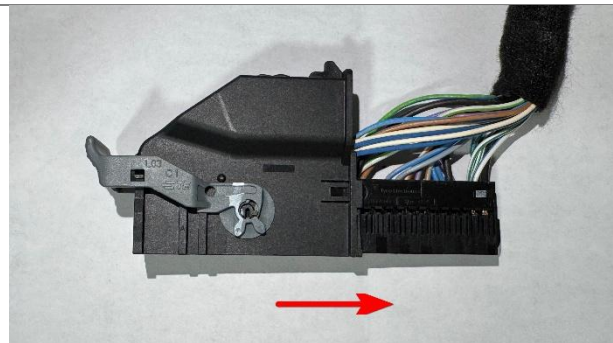

Step 8: Rotate the connector so that the bottom face is oriented toward you. Carefully inspect the exposed inner liner and locate Pin 8 and Pin 38 for reference.

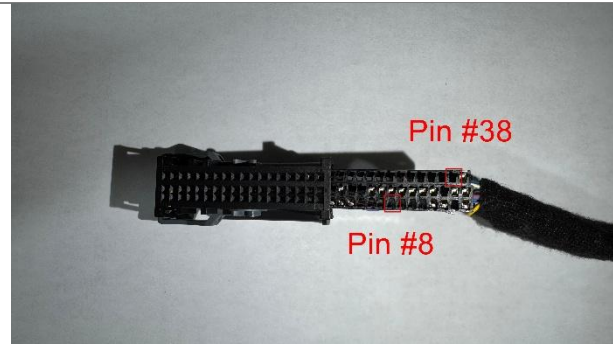

Step 9: Take the USB power jumper wire from the package. Connect the red lead to Pin 8 by firmly inserting it into the corresponding pre-designated slot. Ensure it is fully seated and locked into place. Pay close attention to the slot orientation and the position of the locking tab during installation.

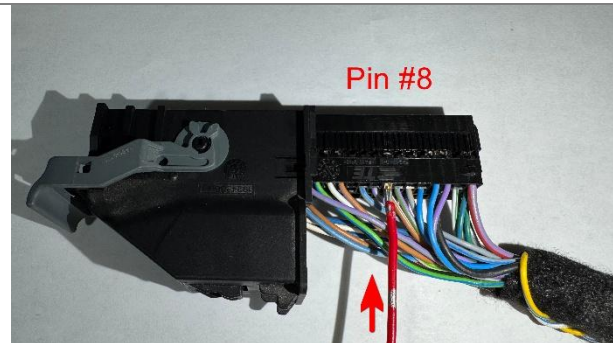

Step 10: Following the same procedure, insert the black wire with terminal into the pre-designated Pin 38 slot. Ensure it is fully inserted into the reserved cavity and securely locked in place.

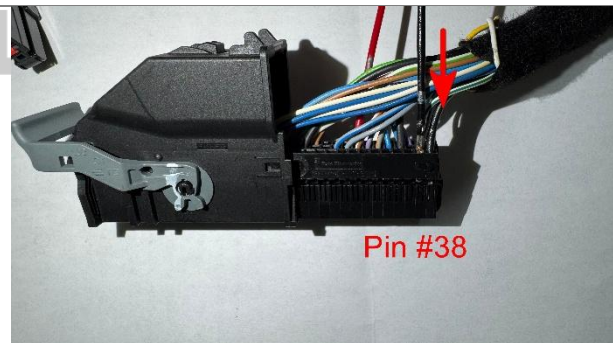

Step 11: After both wires have been individually installed, slide the inner liner back into the connector housing. The two locking tabs will automatically engage and secure the assembly in place.

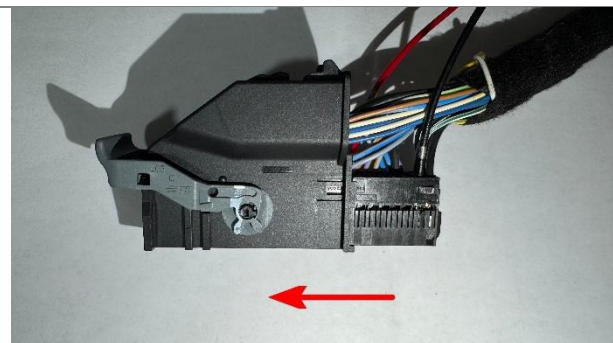

Step 12: After completing the connector modification, the final installation should appear as shown in the reference image. We recommend securing the red and black leads with electrical tape, and bundling the initial breakout section of the modified wires to the main harness. This helps prevent excessive strain or accidental pulling, which could lead to wire damage or disconnection.

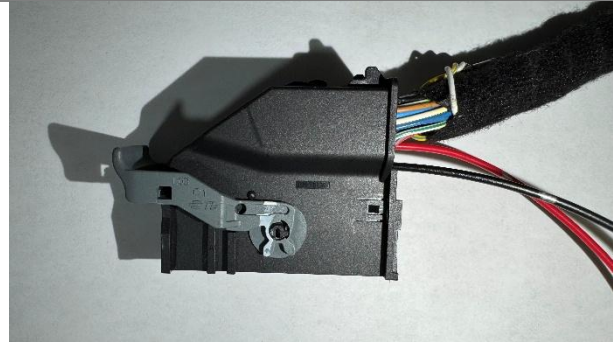

Step 13: Reinstall the modified 54-pin connector back into the APIM module. Ensure it is fully seated and secured using the locking tab. The connector modification process is now complete.



Step 14: Using a 7mm ratchet socket, remove the two screws securing the top trim panel.

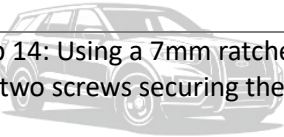

Step 15: Use your interior trim panel removal tool to release and remove the top trim panel.

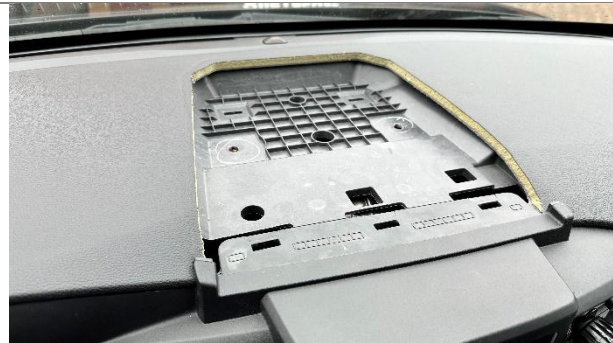

Step 16: Locate the trim cover positioned beneath the instrument cluster and directly above the steering column.



Step 17: Use your hand to lift the trim cover upward, releasing the fourth clip gently. Once the clip disengages, place the trim cover on top of the steering column.



Step 18: Use your interior trim panel removal tool to remove the entire screen frame, then carefully flip it over. On the backside, you will find several electrical connectors—disconnect all of these connectors.



Step 19: Using a T20 Torx bit, remove the screws securing the 4.2-inch screen. Once all screws are removed, carefully lift and remove the entire screen from its housing.



Step 20: As shown in the illustration, position the base plate from the upgrade package into the screen housing, following the orientation depicted in the image. Once fully seated, you will hear a “click”, indicating that the base plate is securely locked into the original housing.

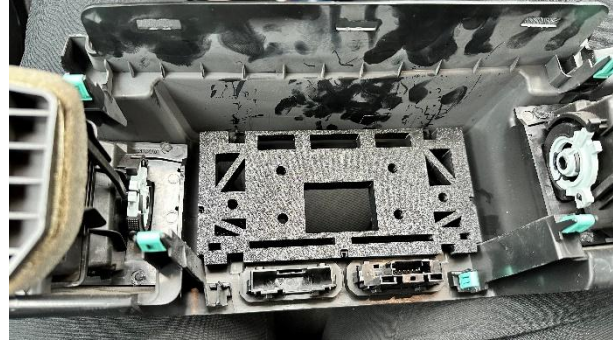

Step 21: Flip the entire screen bezel over to the front side. The base plate will fit perfectly within the original 4.2-inch screen frame. You will notice that the three central sections of the base plate slightly protrude above the screen frame, indicating that the base plate is correctly and securely seated inside the screen bezel.



Step 22: Insert the six M6×40mm mounting bolts into the six pre-drilled holes of the middle plate. Ensure that the hex heads of all six bolts fit perfectly into their respective holes, and that the surface of the middle plate remains flush—there should be no protrusion from the bolts, keeping the entire surface smooth.

Note: If you encounter any installation difficulties, please refer to Section 6.2 for guidance.

[Illustration will be provided soon]

Step 23: Position the screen bezel so that the two pre-drilled holes on each side—left and right—are oriented correctly. On each side, the upper pre-drilled hole, which is closer to the top edge of the screen frame, should be positioned upward, while the lower pre-drilled hole, which is farther from the bottom edge of the screen frame, should be positioned downward. Ensure this orientation is correct before inserting the screen into the bezel.

Note: If you encounter any installation difficulties, please refer to Section 6.2 for guidance.

[Illustration will be provided soon]

Step 24: Place the previously assembled middle plate into the screen and screen bezel assembly as shown in the illustration. At this stage, you will see that the screen's yellow connector passes neatly through the designated opening in the middle plate. Then, secure the entire screen assembly using four M4×10 screws, inserting them into the four pre-drilled holes on the left and right sides of the screen to firmly fix the assembly in place.

Note: If you encounter any installation difficulties, please refer to Section 6.2 for guidance.

[Illustration will be provided soon]

Step 25: Insert the back of the complete screen assembly into the previously installed base plate and screen bezel combination. Align the six M6×40 bolts to pass through the base plate, then secure them on top with the corresponding washers and nuts.

Note: If you encounter any installation difficulties, please refer to Section 6.2 for guidance.



Step 26: Reconnect all previously removed electrical connectors to the screen assembly. Once every connector is fully seated, reinstall the entire assembly back into its original position on the vehicle's front dash and refit the top trim panel securely. Then reinstall the two 7mm mounting screws.

Note: If you encounter any installation difficulties, please refer to Section 6.2 for guidance.



Step 27: Reconnect the vehicle's power by reinstalling the battery terminal. Once power is restored, you must cycle the vehicle power. Insert the key into the ignition cylinder and turn it to the ON position—do not start the engine. After the vehicle powers up, immediately turn the key back to the OFF position. Then start the vehicle normally. At this point, the SYNC 3 system should power on, the Ford logo should appear on the screen, and the system will boot directly into SYNC 3.

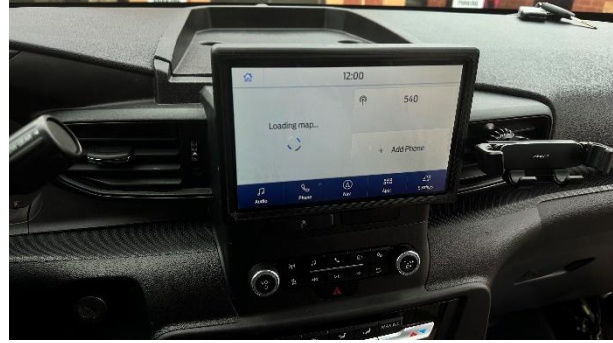

Step 28: Connect the USB Hub-to-APIM cable from the kit. Plug one end into the APIM USB port and the other end into the USB hub. In addition, connect the newly added USB power jumper wire from the modified 54-pin APIM connector to the USB hub, ensuring all connections are fully seated and secure.

[Illustration will be provided soon]

Step 29: Reinstall all panels and trim pieces back into their original positions by following the reverse order of removal. After ensuring everything is properly secured and aligned, perform a final cleaning of the work area and interior. This completes the entire installation process.

[Illustration will be provided soon]

⚠ Important: If you require additional programming, upgrading the SYNC 3 software to the latest build, or any custom programming, please contact us directly. We will schedule a programming session and arrange technical support to assist you with these tasks.

6.2 Detailed Display Installation Process

The following pages provide detailed visual and text instructions for installing the display assembly.

Step 1: Preparation

- Ensure the display is in the face-up orientation before installation.
- Select the appropriate screws based on your display size:
 - 8.46" display: 6 × M6 x 35mm full-thread screws
 - 10.1" display: 5 × M6 x 40mm full-thread or half-thread screws

8.46" Option

Mounting Bezel →
Middle Plate →
Base Plate →

**10.1" Option**

Mounting Bezel →
Middle Plate →
Gap Plate →
Base Plate →

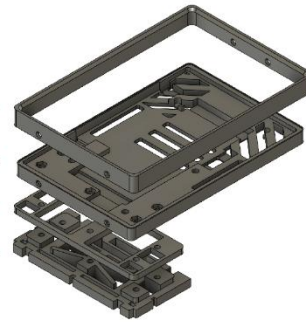

POLICE-LAB

Step 2: Install Mounting Screws

- Insert the M6 screws into the middle plate through the desired mounting holes.
- Push each screw all the way in until the thread is fully protruding from the opposite side.

Step 3: Position the Display

- Place the display on the middle plate.
- Ensure the yellow display connector on the back side of the display fits properly into the blank recessed area on the middle plate, which is reserved for the display port.
- The display should now sit flush with the middle plate.

8.46" Option

Display should be placed between the mounting bezel and middle plate →

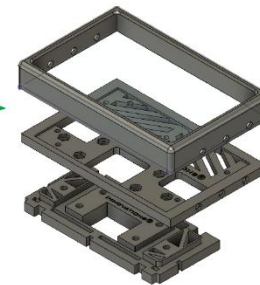

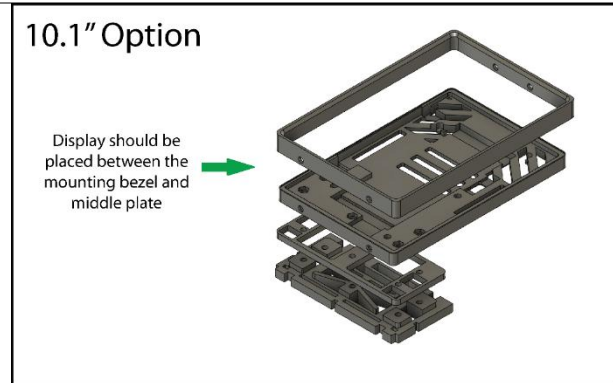

Step 4: Attach the Mounting Bezel

- Place the mounting bezel over the display and middle plate assembly.
- Align the side screw holes on the bezel with the corresponding holes on the middle plate's surround edge.
- Secure the bezel using the correct screws:
 - 8.46" display: 6 × M4 x 10mm screws
 - 10.1" display: 4 × M4 x 10mm screws

Step 5: Install the Base Plate

- Position the base plate inside the vehicle's original display bezel.
- Make sure the protruding surface of the base plate faces outward and fully pushed in until hearing the click sound.
- For the 10.1" display option only: insert the provided gap plate to create clearance for the display cable to pass through the mounting solution.

Step 6: Secure the Assembly

- Align the protruding M6 screw threads from the display + middle plate + bezel assembly with the mounting holes on the base plate.
- Push the screws fully through.
- On the opposite side, secure each screw with the provided M6 washers and nuts.

Step 7: Connect and Finalize

- Connect the display cable to the display.
- Carefully reinstall the entire assembly back into the vehicle's dashboard.

6.3 Video Tutorial

For detailed removal and installation process, you may refer to the video & our YouTube channel by scanning the QR code below:

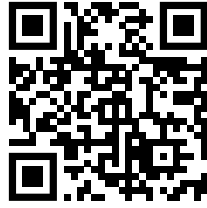

POLICE-LAB

7. Vehicle-Specific Advisory

N/A



POLICE-LAB

8. Post-Installation Setup

After all components have been installed and secured, reconnect the vehicle's negative battery terminal and place the ignition in accessory mode to initiate system startup. The SYNC 3 interface should boot within 10 seconds, displaying the Ford splash screen followed by the home interface. At this stage, confirm that the touchscreen is responsive, audio is functioning through factory speakers, and the upgraded USB ports are active and recognized by connected devices. Steering wheel controls, including volume, voice, and track selection, should operate seamlessly with the new interface. If equipped with a backup camera, shift the vehicle into reverse to verify camera feed and dynamic guidelines. For navigation-enabled systems, allow up to 90 seconds on first boot for the GPS antenna to acquire satellite signal and display accurate mapping. Pair your smartphone via Bluetooth and test voice control functionality. For Apple CarPlay or Android Auto integration, connect the device using a certified high-quality USB cable and follow on-screen prompts. If any abnormal behavior occurs, such as slow response or connection failure, a SYNC master reset may be performed via the system's General Settings menu. It is recommended to complete a final inspection of all panel fitments and wiring security, ensuring no harnesses are left exposed or routed near heat or moving mechanical components. Once verified, the installation is considered complete, and the system is fully operational with no additional programming required. The upgraded system remains fully compatible with Ford diagnostic tools and vehicle systems, preserving OEM functionality and vehicle network integrity.



POLICE-LAB

9. Module Programming & Update

To complete the installation, you will need to download and activate an app called **FORScan** with a trial extended license, purchase the required hardware cable, and then flash the provided **AB (As-Built) file** into your vehicle's module. Please follow the steps below carefully. You can choose to flash the AB file yourself by following the steps below, or you may contact us and we can set up a remote programming session to help you complete any additional programming.

⚠ Important: Always ensure your vehicle battery is stable during programming (consider using a battery charger). Do not disconnect the cable or turn off ignition during flashing. Only load the AB file provided by us — using incorrect files may damage your module.

Step 1: Open your web browser and go to forescan.org. Once on the main page, click on the Products tab at the top, then select the first option "FORScan for Windows" to download the newest release.

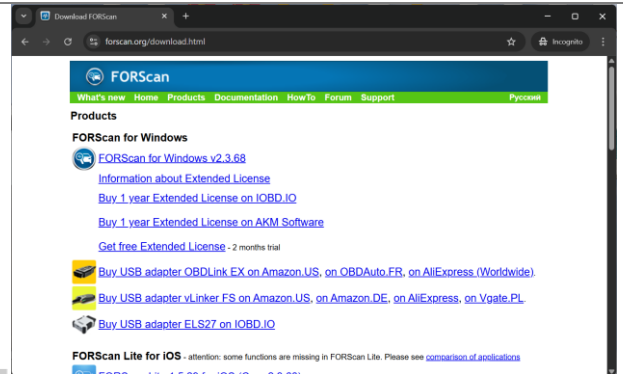

POLICE-LAB

Step 2: After downloading the software, install it on your computer as you would with any standard application. During installation, Windows Defender may display a security or antivirus warning—please allow all actions so the software can install successfully. Once installed, launch the program and enter the main interface.

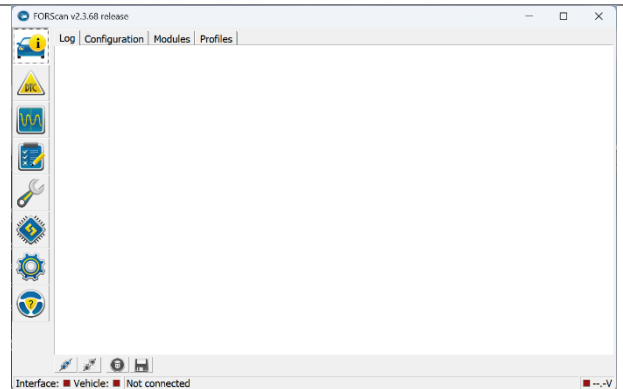

Step 3: On the left toolbar, click the second-to-last settings icon, then open it and disable Demo Mode.

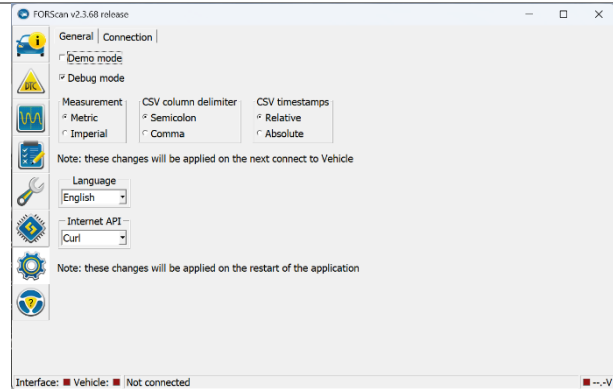

Step 4: On the left toolbar, click the last icon (the steering wheel with a question mark). Locate the Hardware ID line, then click Copy to Clipboard.

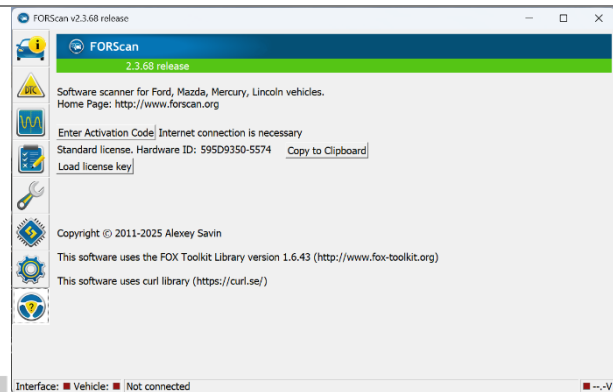

POLICE-LAB

Step 5: Return to the FORScan website, go to the Products tab, and click the fifth option: Get free Extended License – 2 months trial. Then fill in your information, paste the Hardware ID you copied earlier into the Hardware ID field, and click the Submit button at the bottom. The page will notify you that your request has been added to the processing queue. Do not close this page. After approximately 20–30 minutes, return to the page and click Refresh. At this point, the page will show that your Free Extended License is ready. Simply click to download it and save the file to your preferred folder.

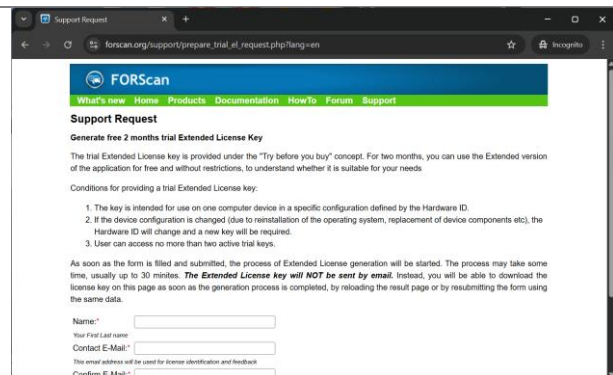

Step 6: Return to the FORScan software. In the left toolbar, open the last icon—the steering wheel with a question mark. Click Load License Key, and a Windows File Explorer window will appear. Navigate to the folder where you saved the downloaded license file, select it, and double-click to load it. FORScan will then prompt you to restart the software. After restarting, FORScan will launch fully activated, giving you two months to perform programming or diagnostic tasks.

Note: Software usage terms apply; please visit the official FORScan website for more information.

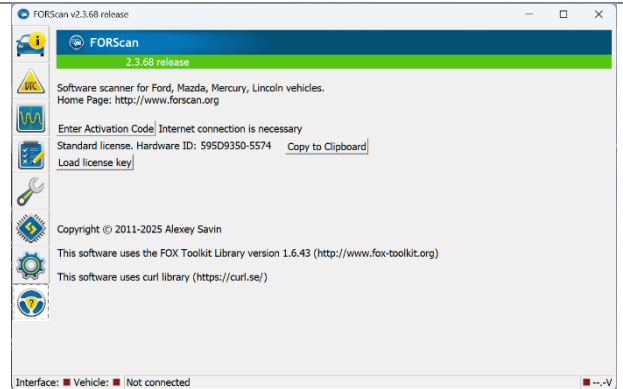

Step 7: Prepare your programming hardware. You will need an ELM327 or a similar diagnostic cable that supports any of the following interfaces:

- Wi-Fi
- COM
- FTDI
- J2534
- Bluetooth

Please refer to the official website for detailed hardware requirements. Connect the diagnostic cable's OBD connector to your vehicle's OBD port, then connect the USB end to your computer. If you are using an ELM327 device, you will see a silver switch near the OBD connector — this switch toggles between HS-CAN and MS-CAN. Before beginning any operations, ensure that the switch is set to HS-CAN. High-end diagnostic cables will not have a switch, as they support automatic CAN signal switching.

Step 8: Flashing the As-Built (AB) File: You will receive the correct AB (As-Built) configuration file for your vehicle via your order confirmation email.

To flash the AB file, return to the FORScan software and follow these steps:

1. Click the third-from-bottom icon on the left sidebar — the computer-chip icon (Configuration and Programming menu).
2. Locate the module that matches the AB file name provided (for example: APIM (As-Built Format)).
3. Select As-Built Format for that module and confirm. Click the Run button in the lower-left corner to enter. Click OK on any warning popup messages.
4. Click Load AB File.
5. A File Explorer window will appear — navigate to the folder where you saved your provided AB file and select it.
6. After the file loads, review the settings.
7. Click the Run button in the lower-left corner again to begin flashing.
8. Wait until FORScan completes the write process. Do not turn off the vehicle or unplug the diagnostic cable during this step.

-
9. Once complete, follow any on-screen instructions to re-cycle your key to finalize all configuration changes.

Step 9: Completion: After the module has been successfully flashed, your new configuration will now be active. You can verify proper functionality by testing all system features associated with the flashed module.



POLICE-LAB

10. Product Label Identification & Retention Requirements

This section only applies if your upgrade package includes a harness manufactured by Police-Lab.

Every harness produced by Police-Lab includes a serialized product label affixed to the primary wiring harness or control module. This label contains critical identification and traceability information and **must remain attached** for the duration of the product's lifecycle. Removal, damage, or defacement of this label will void warranty eligibility and may compromise the ability to provide technical support or product verification.

An example label is shown below:



 S/N 1	
PART NUMBER 2	MFG PLT 4
PRODUCT NAME 3	MFG DATE 5
	QC 6
DO NOT REMOVE LABEL	
<div style="border: 1px solid black; padding: 5px; margin: 5px auto; width: 80%;">WRAP AROUND HARNESS AT THIS SECTION</div> <div style="border: 1px solid black; padding: 10px; margin: 5px auto; width: 60%; text-align: center;"> ATTACH LABEL TO HARNESS 7 </div> <div style="border: 1px solid black; padding: 5px; margin: 5px auto; width: 80%;">WRAP AROUND HARNESS AT THIS SECTION</div>	
<small>WARNING: Do not remove this label. It contains important part and serial number information required for warranty service. This product is intended for use only within specific systems and configurations. Improper installation, unauthorized modification, or use outside of its intended scope will void the warranty and may cause system or vehicle damage. Our Lifetime Warranty covers defects in materials and workmanship under normal, intended use, and applies only to the original purchaser for the duration of ownership. All claims are reviewed individually and may result in repair or replacement as appropriate. For full warranty details and installation support, visit: https://www.police-lab.com/</small>	
	REFER TO MANUAL BEFORE INSTALLATION
	 8

Below is a breakdown of the label fields and their significance:

- **① S/N – Serial Number**
A unique identifier assigned to each production unit for traceability and warranty tracking.
- **② Part Number**
Identifies the exact product version used, linked to the specific application.
- **③ Product Name**
Includes the harness or module name and, where applicable, the exact configuration.

- **④ MFG PLT – Manufacturing Plant Code**
Indicates the internal ID of the production facility and assembly line where the harness was assembled.
- **⑤ MFG DATE – Manufacturing Date**
The date the product was finalized and passed into packaging.
- **⑥ QC – Quality Control Responsible Party**
Indicates the internal ID of the inspector or department that performed final quality control checks before shipment.
- **⑦ Designated Harness Wrapping Area**
The designated area where the labelled should be wrapped to the harness.
- **⑧ QR Code – Product Package Reference**
Scanning this code directs you to the main page on the Police-Lab website.

⚠ Important: Do not remove or relocate this label. It is designed to remain on the designated component (typically the main harness) for warranty tracking and support validation.



POLICE-LAB

11. Warranty and Technical Support

Some components in this upgrade package sold by Police-Lab are covered under our **Limited Lifetime Warranty**, which protects against defects in materials and workmanship under normal, intended use. This warranty applies solely to the original purchaser and is valid only when the product is installed in accordance with the official installation manual. It does not cover damage resulting from improper installation, electrical shorting, unauthorized modification, physical abuse, or use outside of the designated vehicle platform. Any attempt to retrofit this upgrade package into an incompatible vehicle, or to modify included modules, bezels, or harnesses, will immediately void all warranty protections. For complete warranty details, including exclusions and terms, visit www.police-lab.com/warranty or scan the QR code below:

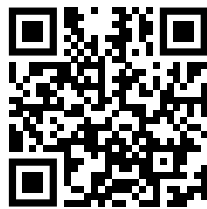

Technical support is available to assist with product-related inquiries, installation questions, and troubleshooting. Our team is available via email and web-based support ticketing during regular business hours (Eastern Time). When contacting support, please be prepared to provide your product serial number, vehicle year and model, and a detailed description of the issue, including installation photos if available. While we do not provide remote programming or vehicle-specific diagnostics, we are committed to helping you resolve any compatibility or installation challenges within the scope of the product. For agencies or fleet customers, priority support is available through our designated technical contact line.

Important: Always retain your original packaging label and proof of purchase, as these may be required for warranty verification.

12. Contact Information

For technical support, product inquiries, or installation assistance, please contact:

Police-Lab

Website: www.police-lab.com

Email: support@police-lab.com

Phone: **+1 (437) 363-6087**

Business Hours: Monday to Friday, 9:00 AM – 9:00 PM EST

Location: 46-16 Regan Rd, BRAMPTON, ON L7A 1C1 CANADA

Our warehouse and assembly facility operate under strict security and operational protocols and, as such, are not open for unscheduled public access. To maintain the integrity of our operations and ensure the safety of our personnel and products, visits to our facility are strictly by appointment only. We encourage all interested parties to contact us in advance to arrange a scheduled visit or consultation, allowing us to provide you with a secure and productive experience.

For fleet agencies, authorized distributors, or partners requiring on-site product demonstrations, technical support, or consultations, we offer dedicated arrangements tailored to your specific needs. Our team is committed to facilitating these engagements with the highest level of professionalism and responsiveness.

Additionally, should you submit a request involving warehouse installation or any on-site service, please be assured that a member of our staff will reach out to you directly to coordinate all necessary details and support.

We appreciate your understanding and cooperation as we uphold these standards to deliver the best service and safeguard our operations.